

# 1911 OWNER'S MANUAL

This is a reproduction of the Instruction Book that came with a new 1911 Model T Ford.

## Instruction Book

for

# Ford Model T Cars

*Ford Motor Company*

Detroit, U. S. A.

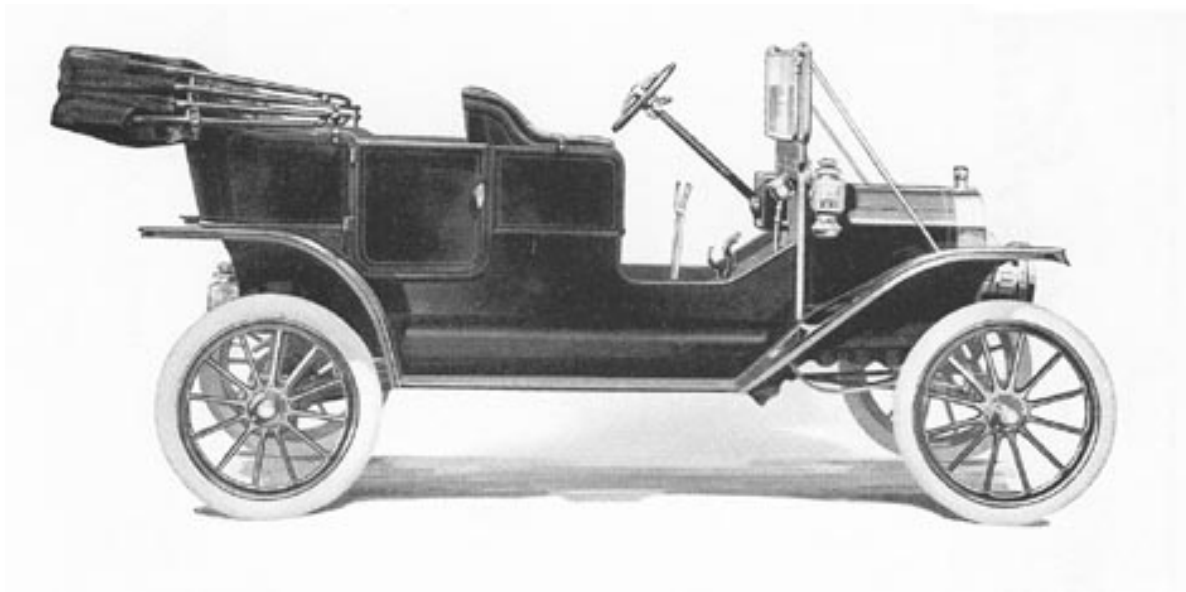

4 Cylinder, 20 Horse Power, 5 Passenger FORD Model T Touring Car  
\$950 f.o.b. Detroit

The following is a reproduction of the *Instruction Book* which was part of the original equipment of the Model T Ford in early 1911. Many of the repair instructions in this book would not apply to later versions of the Model T due to the extensive modifications made in the car in the later 1911 and following models. At the time of this publication the Ford still used the non-tapered rear axle, the open-valve engine, the "square-hole" transmission cover, and a number of other features unique to the 1909 to early 1911 models.

That the new owner would be expected to make the repairs outlined in these instruction books seems surprising in these modern times. How many owners of today's cars would even consider oiling their cars each week, straining their water and gasoline through chamois, or taking up the bearings in the engine?

Present owners will be happy to know that "with the wide range of flexibility which the Model T possesses, there is very little occasion for releasing the high-speed clutch or resorting to low gear under ordinary conditions." (Actually, the pre-1912 Fords had a higher compression and different valve timing than did the later models, and along with their lesser weight, didn't require as much "low pedal" driving on hills.)

But read on. Travel back to the early years of the automobile and relive the trials and tribulations of automobile ownership in the early years of the twentieth century.

## **How to Run the Model T Ford**

WHEN Your Car is Shipped, the tires are inflated; the emergency brake is set; the gasoline tank and the radiator drained, and the valve in pipe leading from gasoline tank to carburetor is closed; the switch on the coil box open, and all magneto and ignition connections made. A little oil is left in the engine base. The wheels are carefully locked to prevent the car getting away and thereby sustaining injury in transit.

Remove the blocks carefully and draw out, or drive down, all nails, so as to avoid injury to the tires. Release the emergency brake and take the automobile out of the freight car, being careful not to mar or scratch the body.

### **WATER**

On Receiving Your Car, and before starting the motor, Fill the Water Tank, which is incorporated in the radiator, with clean, fresh water, preferably straining it through muslin or other similar material to prevent foreign matter getting into the small tubes.

It is important that the car should not even be run out of the freight car under its own power unless the water tank is full. The tank may appear to be full before all parts of the circulation system have been supplied. It will, therefore, be necessary to turn the motor over a few times by hand so as to force water into the cylinder jackets. This will lower it in the radiator. Pour in the water until you are sure both radiator and jacket have been filled and the water runs out of the overflow pipe. During the first few hours that the engine is running, it is a good plan to examine the radiator frequently and see that it is full and the water circulating properly. Soft rain water, when it is to be had in a clean state, is superior to water which may contain alkalis and other salts which are injurious, or which tend to deposit sediment and clog up the radiator.

### **VIGILANCE AND-OIL**

The first rule in motoring is to see that every part has, at all times, plenty of oil---then more oil. The second is to see that every adjustment is made immediately the necessity of such adjustment is discovered; and the third rule is exercise "common sense"---that's what they drive horses with.

The liability of trouble with the consequent marring of pleasure trips through neglect to make adjustments promptly, increases by the square of the times they are neglected.

Permitting any part to run for even a brief period without proper lubrication will certainly result in serious injury to the machine and expense to the owner; and the result of reckless driving, while they may not show up immediately, will none the less certainly appear later, for all that.

### **DO NOT USE GRAPHITE AS A LUBRICANT, AS IT WILL INTERFERE WITH THE PROPER OPERATION OF THE MAGNETO**

If the history of all the joyously anticipated pleasure trips that have ended disastrously could be written, it would be shown that in 90 per cent of the cases the humiliation and disappointment might have been avoided by making a certain repair and adjustment, the necessity of which was known before starting, instead of trusting to luck and a crippled part.

**Use a High-Grade Light Gas Engine Oil**---Poor oil or oil too heavy will smoke, clog up the valves, leave a deposit on pistons.

### **GO IT EASY**

In the flush of enthusiasm, just after receiving your car, remember a new machine should have better care until she "finds herself" than she will need later, when the parts have become better adjusted to each other, limbered up and more thoroughly lubricated by long running.

You have more speed at your command than you can safely use on the average roads, or even on the best roads save under exceptional conditions, and a great deal more than you ought to attempt to use until you have become thoroughly familiar with your machine, and the manipulation of brakes and levers has become practically automatic.

Your Ford car will climb any climbable grade. Do not, in your anxiety to prove it to every one, climb everything in sight. A good rule is, if you crave the fame, climb the steepest grade in your neighborhood once, and let others take your word for it, or the word of those who witnessed the performance, for the deed thereafter.

Extraordinary conditions must be met when they present themselves--- they should not be made a part of the everyday routine.

## **GASOLINE**

The Gasoline Tank is Under the Seat. See that it is supplied with gasoline. Always strain through chamois skin to prevent water and other foreign matter getting into the carburetor. When filling the gasoline tank, extinguish all lamps; throw away your cigar, and be sure that there are no naked flames within several feet, as the vapor is extremely volatile and travels rapidly. Always be careful about lighting matches near where gasoline has been spilled, as the atmosphere within a radius of several feet is permeated with highly explosive vapor.

Unless it has been tampered with, the carburetor adjustment is right, having been set by the head tester, so do not meddle with it until you are certain it needs adjusting. To make adjustment, manipulate button on dash---when leaving factory, adjustment is 0. K., and arrow points up. To give more air, turn to left; for less air, turn to right.

## **OIL**

No mechanical device will operate very long without ample lubrication, neither will the Model "T" cars. Before your car is shipped the oil is drained out of the engine crank case and the oil reservoir. Before starting, the transmission cover should be removed and two quarts of high grade engine oil should be poured into the transmission and a half gallon emptied into the engine crank case through the breather pipe.

Thereafter all oil replenishments are made through breather pipe.

There are two drain cocks in the flywheel casing which acts as the oil reservoir. The oil level should be between these two cocks. If it runs out of the upper, there is too much oil, and it should be allowed to drain out to that level. If on opening the lower drain cock the oil does not run out being at a lower level; a new supply is needed.

Do not use graphite for lubricating engine; its use prohibits the proper operation of the magneto, tending to short circuit same.

Use only a high-grade light gas engine oil---cheap oils are too costly in the end.

The axles, drive shaft and universal joint are well supplied with lubrication when the car leaves the factory, but it is well to examine frequently. For these parts use any high-grade semi-fluid lubricant. It is false economy to use a poor or cheap lubricant at any time.

## **LUBRICATION**

Unless you properly and sufficiently oil every working part of the Model "T" car it is going to operate less satisfactorily than it should, and the trouble is up to you. We are willing to admit that the oiling system demands less attention than the oiling system of any other car, but what is needed must be looked after. The following provisions for oiling the Model "T" have been made.

The oil in the crank case automatically oils cylinders, crank shaft, connecting rods, timing gears, magneto, transmission and in part the universal joint, drive shaft and rear axle system. Use a light high grade gas engine oil and pour it in through the breather pipe in front. Do not use a heavy or even a medium weight oil if you want the maximum service and above all, do not experiment with cheap oils. In the end they cost too much. Keep the level between the two pet cocks in case under fly wheel.

The diagram on the next page points out all the points of lubrication. It's a good plan to frequently supply all oil cups with the same oil used in the engine, though any lubricating oil will answer. and all the dope cups with grease. When filling dope cups it is advisable to fill the cover, screw it down several turns and repeat two or three times. Always open oil cups by turning to right as this keeps tightening rather than loosening them.

Occasionally remove wheels and supply dope to wearing surfaces. A drop of oil now and then in crank handle bearing is necessary also on fan belt pulleys and shaft. Occasionally the control rod and reciprocating parts should be given a small amount of oil.

In short keep all friction surfaces well oiled---otherwise the Model "T" and every other car on earth will give trouble.

### **THE KIND OF OIL TO USE.**

We recommend only light high-grade gas engine oil for use in the model "T" motor. A light grade of oil is preferred as it will naturally reach the bearing surfaces with greater ease, and, consequently, less heat will develop on account of friction. The oil should, however, have sufficient body so that the pressure between the two bearing surfaces will not force the oil out and allow the metal to come in actual contact. Heavy and inferior oils have a tendency to carbonize quickly, also gum up the piston rings and valve stems.

Graphite, or any other form of heavy grease, should not be used as a lubricant in the engine or transmission, as it will have a tendency to short-circuit the magneto.

Dope or grease should be supplied to the differential, front hubs and such other parts as indicated in diagram.

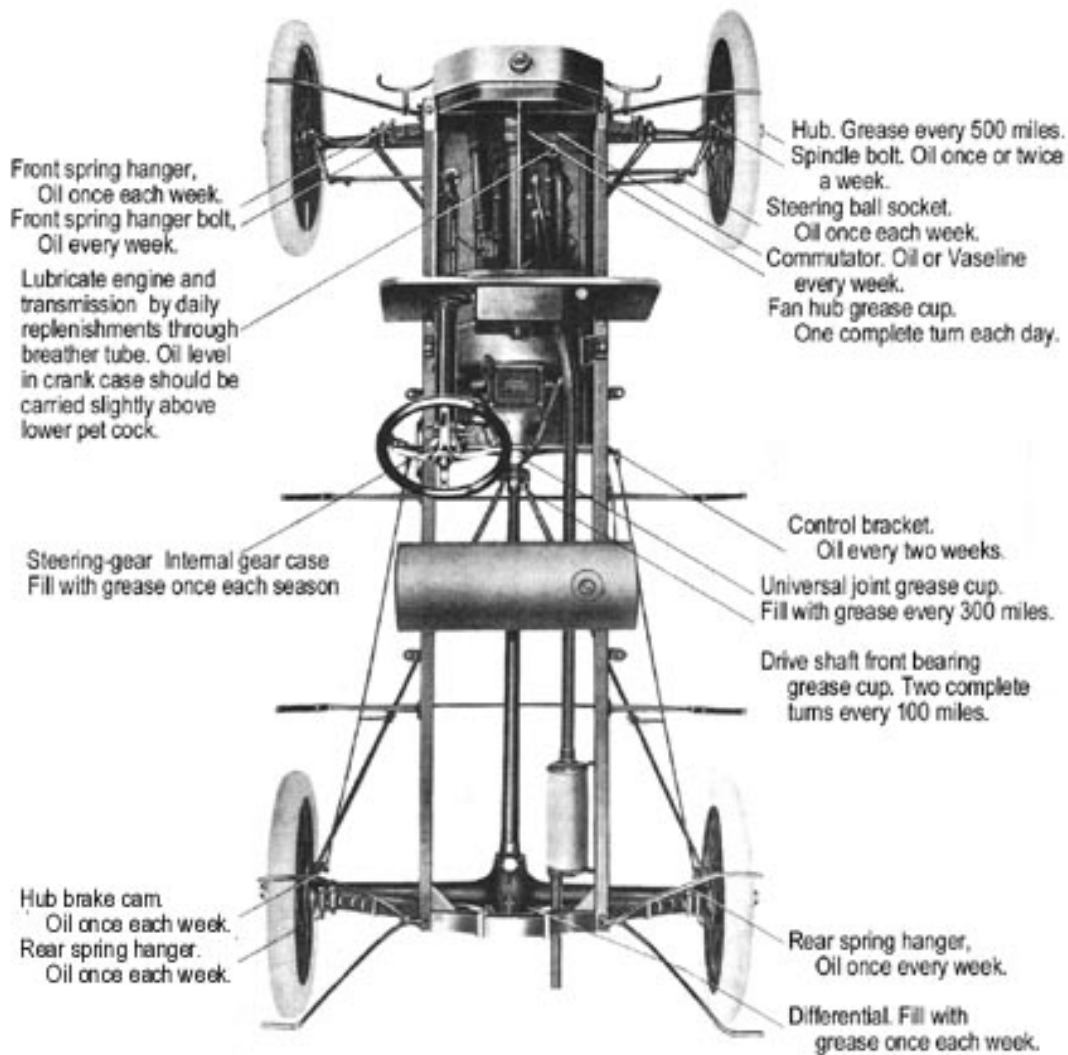

Where to Oil the Model T

## CONTROL

All speeds are controlled by a foot pedal enabling the driver to stop, start, change speeds, or reverse the car without removing the hands from the steering wheel. The foot pedal at the right, operates the brake on the transmission. The pedal in the center, operates the reverse. The left foot pedal, is the control lever acting on the clutch.

The hand lever when thrown forward engages high speed; when pulled back, operates the emergency brake. The lever is in neutral when almost vertical and clutch is in a released condition. With the hand lever thrown forward in high speed, a light pressure on pedal "C" releases the clutch, while a full pressure on the pedal throws into slow speed; by gradually releasing the pedal, it will come back through neutral into high speed.

**Before Starting Out with the Car,** see that there is plenty of gasoline in the tank; the shut-off valve in the gasoline feed pipe open; the radiator filled; the proper amount of oil in the crank ease; the grease cups, oil cups and other parts requiring lubrication given attention.



See that the hand lever is in a vertical position, the clutch I hereby being disengaged and the emergency brake set.

Close the coil switch.

Place the spark lever at about the third or fourth notch of the quadrant--- wherever the best results are obtained.

Open the throttle about five or six notches, and prime the carburetor if the engine requires it.

Engage the starting crank firmly and pull up on it. Two or three times will usually suffice to draw the mixture into cylinders and ignite it.

**To Start the Machine**, slightly accelerate the engine by opening the throttle, place the foot on the clutch pedal, and thereby hold the gears in a neutral position while throwing the hand lever forward; then to start the car in motion, press the pedal forward into slow speed and when under sufficient headway (20 to 30 feet), allow the pedal to drop back slowly into high speed, at the same time partially closing the throttle, which will allow the engine to pick up its load easily. With a little practice the change of speeds will be easily accomplished, and without any appreciable effect on the smooth running of the machine.

**To Reverse the Car**, it must be brought to a dead stop. With the engine left running, disengage the clutch with the hand lever and press the reverse pedal forward with the left foot, the right foot being free to use on the brake pedal if needed.

**To Stop the Car**, partially close the throttle; release the high speed by pressing the clutch pedal forward into neutral; apply the foot brake slowly but firmly until the car comes to a dead stop. Do not remove foot from clutch pedal, without first pulling hand lever back to neutral position. To stop the motor, open the throttle a trifle to accelerate the motor and then throw off the switch. The engine will then stop with the cylinders full of explosive gas, which will naturally facilitate starting.

Endeavor to so familiarize yourself with the operation of the machine that to disengage a clutch and apply the brake becomes practically automatic---the natural thing to do in case of emergency.

When Driving the Car, the spark should be advanced as the speed increases until the engine reaches the highest point of efficiency. If the spark is advanced too far a dull knock will be heard in the motor, due to the fact that the explosion occurs before the piston has completed its compression stroke. The spark should only be retarded when the engine slows down on a heavy road or steep grade, but care must be exercised not to retard the spark to such an extent that over-heating will result. The greatest economy in gasoline consumption is obtained by driving with the spark advanced sufficiently to obtain the maximum speed. The varying speeds required to meet road conditions should be obtained by using the throttle, and with the wide range of flexibility which the model "T" possesses, there is very little occasion for releasing the high speed clutch or resorting to low gear under ordinary conditions.

## CARBON DEPOSIT

This is one of the most fruitful sources of trouble in a gas engine. If the cylinders get too much oil, which they do if the oil level is too high, or you use an inferior or a heavy oil, a portion of it will work up past the pistons and the intense heat will consume or evaporate the oil, leaving a deposit of carbon. This may be augmented by too rich a mixture, which serves to deposit lamp black or carbon in a film on the inside and top of the compression chamber, and on the heads of the pistons. The films thus formed will in time commence to scale, and the projections becoming fused by the heat of explosions will serve to prematurely ignite the charge.

The symptoms of a carbon deposit are back firing and knocking in the cylinders, as if the spark were too far advanced. Another almost infallible evidence of excessive carbon deposit in the cylinders is the motor showing plenty of power at high car speeds, but a lack of power when hill-climbing on high gear. At slow engine speeds the incandescent carbon projections serve to pre-ignite the charge thereby reducing the power of the motor. The cure is to take off the cylinder head and scrape off the carbon deposit from the top of piston and inside of cylinder head.

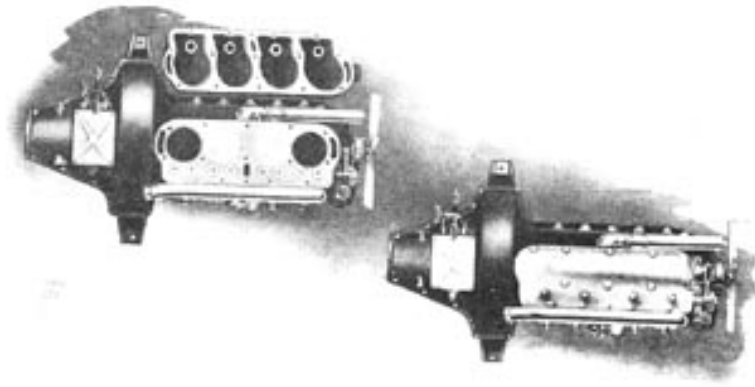

Carbon will also form on the porcelain portion of the spark plugs, thereby furnishing a circuit which the high tension current may travel over rather than jump between the sparking points of the plug. Usually only a part of the current will pass by way of the carbon film, still leaving a weak spark at the points, which in open air, when testing plugs, may seem strong enough. This causes intermittent firing. The symptoms are similar to a poor contact commutator. This condition is difficult to detect for the reason that when the plug is subjected to the usual test of removing the cylinder and closing the electrical circuit the spark is seen to jump free and "fat" between the points. This, because of the electrical energy which is sufficient to jump between two points one-half inch apart in the open air, will jump less than one-sixteenth of an inch in the chamber under 60 pounds compression. If there's any carbon on the spark plug porcelains, clean them.

### **VALVES AND VALVE GRINDING**

Valves should be ground at regular intervals, whether they leak or not. The grinding of the seats will cause them to set accurately and prevent uneven wear of the guides and consequent leaks past the valve stems, a condition which results in loss of power and unevenness in the running of the motor.

Leaky valves make themselves manifest by loss of compression, easily discoverable in cranking the engine.

For grinding purposes, either ground glass or fine emery is commonly used. A convenient way is to put a small amount of emery in a suitable dish, adding a spoonful or two of kerosene and a few drops of lubricating oil to make a thin, watery paste. Place the mixture on the bevel face of the valve, put the valve in position and rotate it back and forth (about a quarter turn) a few times, then lift slightly from the seat to change the position of the valve and continue the operation until the bearing surface is smooth and bright. The valve should not be turned through a complete rotation as it is apt to cause scratches running around the entire circumference. When completed, the valve should be removed from the cylinder, thoroughly washed with kerosene, and the valve seat wiped out thoroughly clean. Extreme care should be taken that no abrasive substance gets into the cylinders. If the valve seat in the cylinder is ridged or in bad shape it is best to have the seat re-trimmed with a valve seating tool. This operation requires considerable skill and care should be exercised against making too deep a cut, necessitating re-timing the valve.

### **VALVE SPRINGS**

When the valves fail to seat themselves promptly the springs may be weak and should be looked after. A weak inlet valve spring makes itself evident by backfiring through the carburetor. A broken inlet valve key will give much the same indication.



Note: When push rod "P" is resting on back of cam between periods of closing and opening of valve, clearance between valve stem "V" and push rod "P" is  $1/32"$

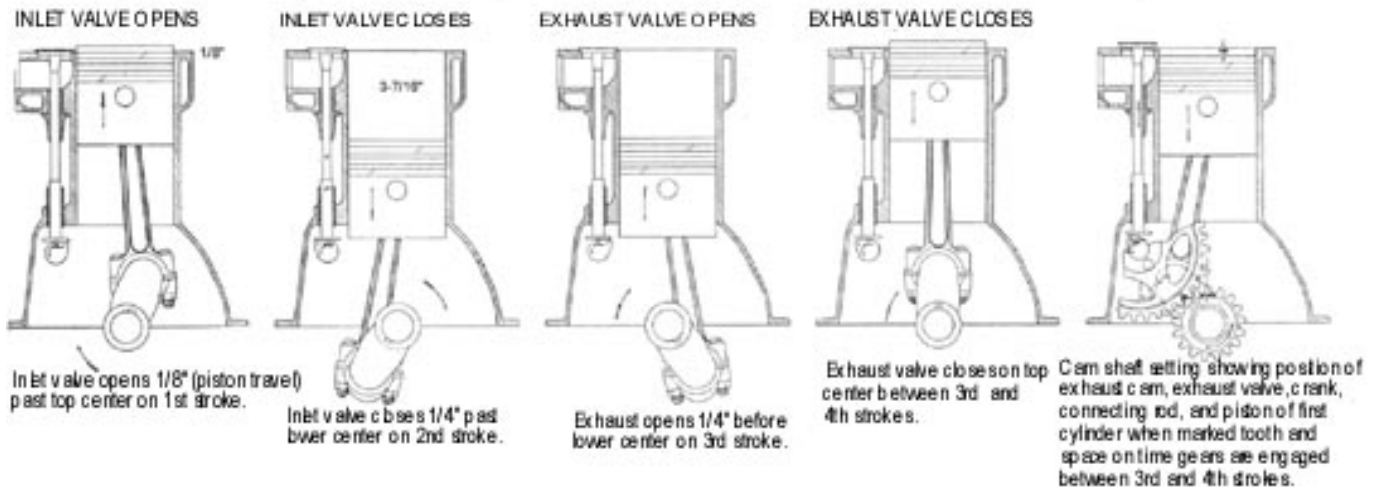

## VALVE SETTING DIAGRAM

(The captions above are difficult to read. The settings shown are: Inlet valve opens  $1/8"$  (piston travel) past top center on first stroke and closes  $1/4"$  past lower center on second stroke. Exhaust valve opens  $1/4"$  before lower center on third stroke and closes on top center between third and fourth strokes. The right side picture caption reads: Cam shaft setting showing position of exhaust cam, exhaust valve, crank, connecting rod, and piston of first cylinder when marked tooth and space on timing gears are engaged between the third and fourth strokes. Valve clearance is specified as  $1/32"$ .)

## VALVE TIMING

This is a matter of considerable importance, as the timing of the valves and the condition of their seats has much to do with the power developed by the engine. The valves are accurately timed at the factory, and the necessity for re-timing usually occurs as a result of wear in the valve seats, valve stems, push rods and timing gears, after the car has been in service for a year or more. If the cam shaft is removed for any reason, care must be taken to replace it, so that the tooth of the small timing gear, indicated by a punch mark, will mesh between the two teeth of the large timing gear at the zero mark. In assembling the cam shaft to the large timing gear, see that the first exhaust cam point is in the opposite direction from the zero mark on the gear. The diagram on the preceding page will show the proper setting of valves, also timing gears.

When valves or valve lifters become worn, so as to leave unusual play between them, thus reducing the lift of the valves and diminishing the power of the motor, one of two things should be done; either replace the push rod with a new one or draw the valve stems out until there is a space about  $1/32$  inch between them. In drawing out the valve stem extreme care must be exercised not to bend it, as this will cause the valve to stick or wear the seat and guide unevenly. The clearance between the push rod and valve stem should never be greater than  $1/32$  not less than  $1/64$  of an inch. If the clearance is greater the valve will open late and close early, resulting in uneven running of the motor. If the clearance is less than  $1/64$  inch there is danger of the valve remaining partially open all the time. If the clearance be too great the valve stem may be drawn out, as shown by the following illustration. If valve stem is drawn out too much it may be cut off. Never draw that portion of the stem above the cotter pin hole, as this decreases the diameter of the stem where it operates in the valve guide, allowing auxiliary air to be drawn in around the valve stem. This gives an improper mixture, and makes it impossible to properly adjust the carburetor.



When necessary to lengthen valve, draw from point "R" as shown by dotted line (below the keeper pin hole).

## COMMUTATOR

The commutator should be examined when ignition trouble arises, to see that it is not worn out, or too "wobbly" on the shaft. To prevent undue wear, a good grade of lubricating oil should be frequently injected into the commutator through the oil hole provided for that purpose.

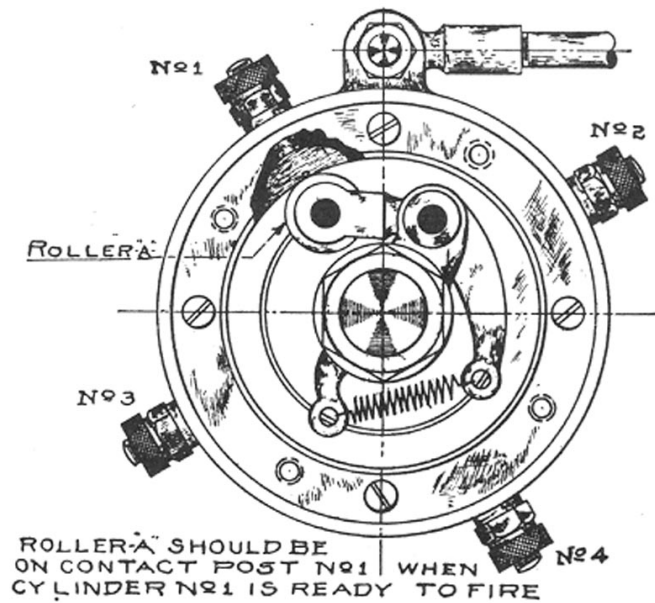

**Diagram Showing Proper Method of Setting Commutator**

To disconnect the commutator, remove the brass cap with a short screwdriver; unscrew lock nut; withdraw steel brush cap; drive out the retaining pin which will allow removal of the commutator from the cam shaft.

In case the fiber, contact points and roller are badly worn, the most satisfactory remedy is to replace them. The spring should be strong enough to make a firm contact between the roller and points.

In replacing the commutator, crank the engine over until No. 2 inlet valve opens wide; then turn the crank just enough to bring the valve two-thirds of the way on the down stroke; set the commutator so that the lead rod connection is in a vertical position, when the roller will be on contact to fire No. 1 cylinder.

## TO ADJUST CRANK SHAFT MAIN BEARINGS

If the engine "knocks" when suddenly thrown into high speed or when pulling up a stiff grade---the spark being properly timed---it is probable that the main bearings require adjustment. For the benefit of those who are not thoroughly familiar with the procedure necessary to correct trouble of this nature, we offer the following directions:

1. With the motor resting on its head, remove the three babbitted caps and clean the bearing surfaces with gasoline. Apply Persian blue or red lead to the crank shaft bearing surfaces, which will enable you in fitting the caps to determine whether a perfect bearing surface is obtained.
2. Place the rear cap in position and tighten it up as much as possible without stripping the bolt threads. When the bearing has been properly fitted, the crank shaft will permit moving with one hand. If the crank shaft cannot be turned with one hand, the contact between the bearing surfaces is evidently too close, and the cap requires shimming up, one or two paper liners usually being sufficient. In ease the crank shaft moves too easily with one hand, the shims should be removed and the steel surface of the cap filed off, permitting it to set closer.
3. After removing the cap, observe whether the blue or red, "spottings" indicate a full bearing the length of the cap. If "spottings" do not show a true bearing, the babbitt should be scraped and the cap refitted until the proper results are obtained.
4. Lay the rear cap aside and proceed to adjust the center bearing in the same manner. Repeat the operation with the front bearing, with the other two bearings laid aside.
5. When the proper adjustment of each bearing has been obtained, clean the babbitt surface carefully and place a little lubricating oil on the bearings, also on the crank; then draw the caps up as closely as possible---the necessary shims, of course, being in place. Do not be afraid of getting the caps too tight, as the shim under the cap and the oil between the bearing surfaces will prevent the metal being drawn into too close contact. If oil is not put on the bearing surfaces, the babbitt is apt to cut out when the motor is started up before the oil in the crank case can get into the bearing.

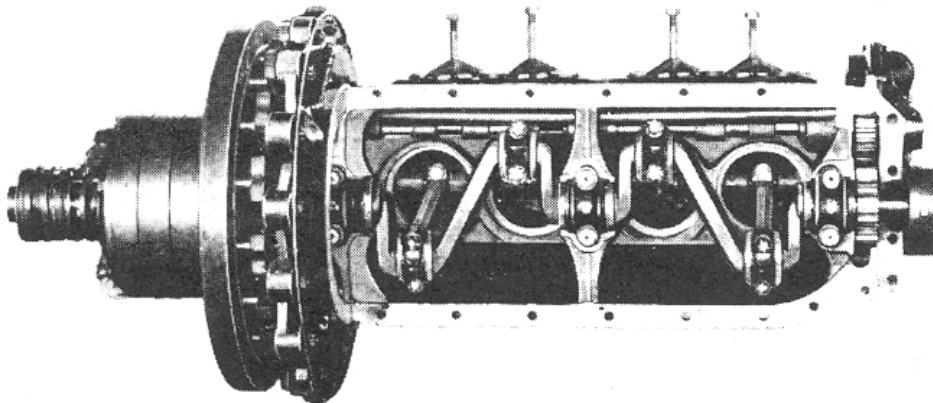

**TO ASSEMBLE TRANSMISSION**

With the transmission shaft (3331) in place, turn the flywheel face downward so that the shaft will be in a vertical position.

Then assemble the following parts in a separate group proceeding as follows:

Place brake drum (3311) on table with the hub in a vertical position; place the slow speed plate (3306) over hub with gear uppermost; then place reverse plate (3301) over the slow speed plate so that the reverse gear surrounds the slow speed gear; fit the two keys (3318) in hub just above slow speed gear; put the driven gear (3317) in position with teeth downward so they will come next to slow speed gear. Next take the three triple gears (3313) and mesh them with the driven gear, according to punch marks on the teeth, the reverse gear or smallest of the triple assembly being downward. After making sure that the triple gears are properly meshed, tie them in place by passing a cord around the outside of the three gears. Then invert this assembled group over the transmission shaft, and place in position so that the fly-wheel pins will pass through the triple gear. This will bring the brake drum (3311) on top, in position to hold the clutch plates, etc.



The next step is to fit the clutch drum key (3333) in the transmission shaft: press the clutch drum (3332) over shaft and put set screw (3334) in place to hold the drum. Put distance plate (3330) over the clutch drum, then the small thrust plate (3328) alternating with the large thrust plates (3329) until the entire set of plates are in position. Then put the clutch push ring (3336) over the clutch drum, with the three pins projecting upward, and lastly bolt the driving plate (3321) in position so that the adjusting screws of the clutch fingers will bear against the clutch push ring pins.

Before proceeding further, it would be a good plan to test the transmission by moving the plates with the hands.

The clutch parts may be assembled on the driving plate hub as follows: Slip the clutch shift (3344) over the hub so that the small end rests on the ends of the clutch fingers. Next put on the clutch spring (3340) placing the clutch support (3341) inside, so that the flange will rest on the upper coil of the spring. Next place clutch spring thrust ring (3343) with notched end down and press in place--- inserting the pin (3342) in the driving plate hub through the holes in the side of the spring support. The easiest method of compressing the point necessary to insert the pin is to release the tension of the clutch fingers by means of the adjusting screws. When tightening up the clutch again, the spring should be compressed to within a space of two or two and one-sixteenth inches to insure against the clutch slipping. Care should be exercised to see that the screws are adjusted so the spring is compressed evenly all around.

## WHEELS

The wheels should be jacked up periodically and tested, not only for smoothness of running, but for side play as well. If in spinning a front wheel a sharp click occurs now and then and the wheel is momentarily checked, it is probable that there is a chipped or split ball in the bearing which should be removed. Otherwise it may necessitate the removal of the entire bearing. A wheel in perfect adjustment should after spinning come to rest with the tire valve directly below the hub.

Undue wear of the hub bearings, such as cones, balls and races, is usually caused by lack of lubrication and excessive friction, due to the adjusting cone being screwed up too tight. It is a good plan to clean the bearings frequently and keep the hub well filled with grease.

It will be observed that the front wheels are "dished;" that is the spokes are given a slight outward flare to enable them to meet side stresses with less rigid resistance. The wheels are also placed at an angle---that is to say, the distance between the tops of the front wheels is about three inches greater than between the bottoms. This is to give perfect steering qualities and to save wear on the tires when turning corners. The wheels should not, however, "toe in" at the front. Lines drawn along the outside of the wheels when the latter are straight in a forward position should be parallel. The wheels should always be kept in proper alignment, otherwise steering will be difficult and tire wear greatly increased. Adjustment can be made by turning the yoke at the left end of the spindle connecting rod, to draw the wheels into a parallel position.

### **COIL ADJUSTMENT**

This is a comparatively simple matter, and with a little practice perfect adjustment can be secured. The usual method is to turn the adjusting screw down until the vibrator stops buzzing; then turn the screw back slowly until a good spark is obtained. It is important to have all the units adjusted alike, and with a little experience you will be able to "feel" by the explosions when the point is reached at which the motor develops the maximum speed. Too close contact between the adjusting screw and vibrator will cause the current to "arc" between the platinum points, thus hindering the flow of the current, burning away the platinum and often putting the coil out of action. This may be remedied by cleaning the points with paper or fine emery cloth. If the platinum points become pitted or worn so that imperfect contact is made, they should be filed flat with a thin watchmaker's file, so that the surfaces meet each other squarely.

With the vibrators properly adjusted, if any particular unit fails, or seems to develop only a weak action, change the position of the unit to determine if the fault is actually in the unit. Remember that a loose wire connection, faulty spark plug, or worn commutator may cause irregularity in the running of the motor, which are points that should be considered before laying the blame on the coil. The first symptom of a defective coil is the buzzing of the vibrator with no spark at the plug. A leak in the condenser is often indicated by a "fat" bluish spark, but to make sure this is the cause of the trouble, put a spark gap of about one-thirty-second of an inch between the secondary wire and plug. If the condenser leaks, the spark will be irregular at the gap.

### **OVER-HEATING**

When the motor over-heats and the water boils many car owners are only too ready to blame it to insufficient water capacity, when in reality the water capacity is ample and the difficulty is due to some outside influence.

1st. The quality of the oil affects the cool operation of the motor. An inferior grade of oil will leave a deposit of carbon on the piston heads, valves, etc., which may result in pre-ignition and pounding, as well as over-heating.

2nd. Running on an open throttle and a retarded spark-usually resulting in a red-hot exhaust pipe will cause the motor to heat, while an advanced spark will not only save gasoline, but cut down heat.

3rd. The radiator or cylinder water jackets may be partially stopped up because of dirt in the water or a deposit from it. The remedy is to disconnect water connections, top and bottom, and thoroughly flush radiator and water jackets with water under pressure from the hydrant, running it in at the top and out at the bottom. A slipping fan belt may also cause the water in the radiator to overheat. On pump cooled motors be sure the pump is operating. A sheared pump pin, for instance, may have rendered the pump inactive.

4th. Too rich a gas mixture will be indicated by black smoke coming from the exhaust. This condition may be due to the carburetor float being adjusted too high, or the gasoline valve not seating properly. A clogged muffler which prevents the hot gases escaping readily will also tend to over-heat the motor.

### **IRREGULAR IGNITION**

The occasional miss in one or more cylinders is apt to be ascribed to the magneto just because the proper reason is difficult to understand. The "missing" of explosions results in an uneven running of the motor, and it can usually be traced to its source by following these directions:

To ascertain which, if any, of the four plugs are fouled with oil, short circuited with carbon, or inoperative from some other cause, open the throttle two or three notches to speed up the motor; now hold your two fingers on two outside vibrators so that they cannot buzz. The evenness of the exhaust will show that the other two are working correctly and that the trouble is not there; or an uneven exhaust will indicate that it is between the two that are free. If the two cylinders fire evenly change the fingers to the two inside vibrators and again listen to the exhaust. Having ascertained in which pair the trouble is, hold down three fingers at a time until you find the one on which the motor does not fire. Cylinder No. 1 is the front cylinder, and they number in rotation 1-2-3-4. No. 1 coil unit is the one farthest from the steering post and they number 2-3-4 to the left. Then remove the spark plug and clean the core. Replace plug, taking precaution that all connections are correct and tight. If missing continues, put in a new plug.

If this procedure does not locate the trouble, we would suggest that you disconnect that particular cylinder wire from the coil and ground the spark plug end to some part of the engine. Hold the other end of the wire near the coil terminal and if sparks are produced it is evident there is nothing wrong with the coil. As a further test, try changing positions of the coil units in the box. Also inspect the platinum points on the vibrators and contact points, as they may be partially burned away or badly pitted.

When mis-firing occurs particularly when running at high speeds, it would be advisable to inspect the commutator, as the fiber may be worn so that the roller touches only the high spots, or it may be that the roller has worn out of round and consequently forms imperfect contact on all of the points.

Irregular ignition and unevenness in the running of the motor, particularly at slow speeds, is apt to be the result of improperly seated valves or a leak in the carburetor or cylinder head gaskets. A weakness in compression may be detected by lifting the starting crank slowly the length of the stroke for each cylinder in turn. In rare instances an exhaust valve may become warped by the engine becoming over-heated, in which case the valve seat will have to be reground or the valve replaced.

It sometimes happens that symptoms of weakness in the ignition system are due to the magneto terminal spring in the transmission cover becoming covered with waste or iron filings, which it attracts from the crank case. This will naturally hinder the action of the current, and may stop the motor entirely.

You have undoubtedly observed in advancing the spark-lever, that there are certain notches in the quadrant (known as cut-outs on the magneto) at which the motor does not respond with increased speed as naturally would be expected; whereas by placing the lever one or two notches in either direction this is overcome. It is advisable to locate these "dead points" by marks on the quadrant and avoid placing the spark lever in such positions when cranking or driving the machine.

### **CLUTCH ADJUSTMENT ON THE MODEL "T"**

If the clutch slips, the difficulty may be due to the threaded pedal connection (3445) being too tight, and by lengthening same one or two turns the proper adjustment can be secured.

Another method of clutch adjustment is provided by means of the adjusting screws in the, clutch fingers---giving each screw an equal number of turns to the right tightens the clutch. After a considerable period of service, the wear in the clutch may be taken up by installing another pair of clutch discs (3325 and 3329) rather than by turning the adjusting screws in too far.

If the clutch pedal, when pushed forward into slow speed, has a tendency to stick and not come back readily into high, tighten up the slow speed hand as directed below: Should the machine have an inclination to creep forward when cranking, it indicates that the clutch lever screw which bears on speed lever (3432) has worn, and requires an adjustment to keep the clutch in neutral position.

### **SLOW SPEED, BRAKE AND REVERSE BAND ADJUSTMENT**

The slow speed band may be tightened by loosening the lock nut on the right side of the transmission cover, and turning the adjusting screw (A) (3419) to the right. To tighten the brake and reverse bands, remove the transmission case cover, and turn the adjusting nuts (B and C) on the shafts to the right. See that the hands do not drag on the drums when disengaged, as they exert a brake effect, and tend to overheat the motor. The bands, when worn to such an extent that they will not take hold properly, should be re-lined with raybestos material so that they will engage smoothly without causing a jerky movement to the car.

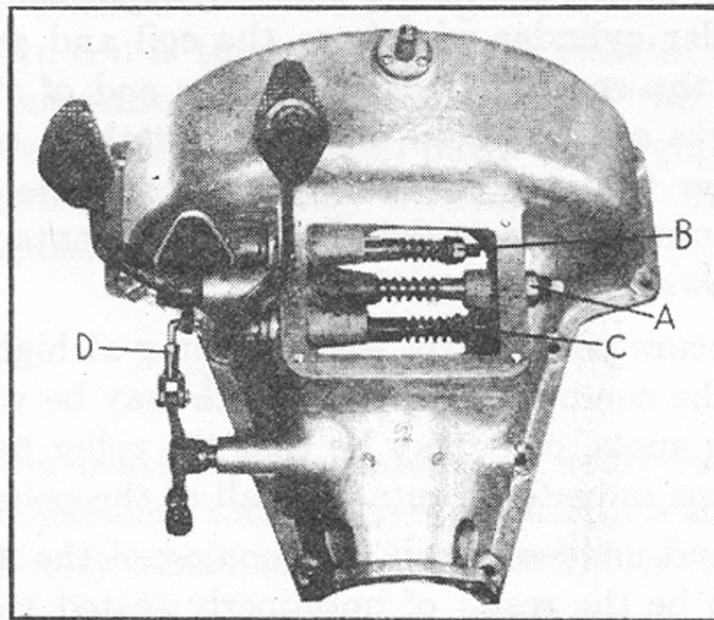

**TO REMOVE TRANSMISSION BANDS**

Take off the door on top of the transmission cover and run the clutch band adjusting nuts (B and C) to the extreme ends of the brake and pedal shafts; then remove the slow speed hand adjusting screw A; loosen bolts holding transmission cover; take hold of slow speed pedal and lift off the cover assembly. Slip hands forward, sliding the one nearest the fly wheel over the first of the triple gears; turn the bands so that the ears are down, then pull them out. To do this requires the spreading apart of the hand at the ears and is more easily accomplished if the three sets of triple gears are so placed that one set is about ten degrees to the right of the center at top. To replace, reverse this procedure, and when fitting the transmission cover see that the clutch release ring (3400) rests into the rear groove of the clutch shift.

### FRONT AXLE

To remove front axle, jack up front end of car so wheels can be removed, disconnect steering gear, disconnect radius rods at ball joint and remove two cotter-pinned bolts from shackle on each side, so detaching front spring.

To disconnect radius rods from axle, remove cotter-pinned nuts. To remove entirely, take out two bolts and ball joint and remove lower half of cap.

Once every thirty days the axle should be carefully gone over to see that every moving part, such as the bushings in spring connections, spring hangers, steering knuckles and hub bearings are thoroughly lubricated, and that all nuts and connections are secure with cotter pins in place.

The spring clips, which attach the front spring to the frame, should be inspected frequently to see that the nuts are not working loose, as this will permit the axle to slip sidewise, interfering with the steering, and may result in an accident when turning suddenly.

**Bent Steering Knuckle.** Should a steering knuckle become bent, it is necessary to have a large gauge or jig to straighten it accurately. The eye is not sufficient to determine whether it is correct; and excessive wear of the front tire will be the result of inaccuracy in this place. In all cases, it would be better to send to us for correction.

### STEERING GEAR

The gears which are arranged in the "sun and planet" form are located at the top of the post just below the hub of the wheel. By loosening the set screw and unscrewing the knurled brass cap-after having removed the steering wheel, they may readily be inspected and replenished with grease.

To remove steering wheel, unscrew the brass nut on top of the post, remove key and draw the wheel off.

To take up wear in steering gear, disconnect the two halves of the ball sockets and file off faces until they fit closely around the ball. If ball is badly worn it is safest to replace it with a new one.

To remove steering shaft, remove pin and disconnect steering arm from bottom of post. Unscrew knurled cap from gear housing, lift off wheel with center pinion; push shaft upwards.

### MUFFLER

To disconnect the muffler it is not necessary to disconnect the exhaust pipe from the motor (although it is a good plan and a simple matter, necessitating only unscrewing the union), disconnect muffler from frame, unscrew union at forward end of pipe, drop down so it will clear the frame and slip back off the tube.

To clean muffler, remove nuts on ends of rods which hold muffler together and dis-assemble. To re-assemble muffler, reverse above operation, being careful not to get the holes in the different sections opposite each other.

### REMOVE REAR AXLE



Jack up car so that wheels hang free. Take out four cotter pinned castle nutted bolts connecting two halves of universal ball collar. Disconnect brake rods.

Remove rear wheels by unscrewing hub cap using special hub wrench furnished with car. Drive out pin; pull out key with pliers; pull off wheel.

To dis-assemble rear axle and differential, disconnect drive shaft tube by removing nuts in front ends of radius rods; draw away the tube; remove bolts which hold two halves of differential housing together, and draw housing apart.

If necessary to dis-assemble differential gear, a very slight mechanical knowledge will permit one to immediately discern how to do it once it is exposed to view. Care must be exercised to get every pin, bolt and key lock back in its exact position when re-assembling.

**To Remove Drive Shaft Pinion.** In order to make a "fool proof" and absolutely reliable job, the drive pinion is keyed onto the shaft and the end of the shaft riveted over. If it is desired to replace the pinion, it may be removed from the shaft by cutting away the edges where riveted over and driving out the shaft.

In replacing, rivet over the end of the shaft as well as possible and be sure that the gear is on perfectly straight, as otherwise it is sure to cause trouble by not meshing accurately.

**To Remove Large Driving Gear.** Take out the cap screws holding gear to differential case.

**To Disconnect Universal Joint from Drive Shaft.** Remove two plugs from top and bottom of ball casting. Revolve shaft until pin comes opposite hole; drive out pin and drive universal joint away.

Wear in the universal joint may be taken up by disconnecting the two halves, cutting off the rivets with a cold chisel and carefully filing or turning down the faces so as to allow them to come together. The hole will not then be perfectly round and should be carefully scraped or reamed to fit. Excessive wear in the steel parts calls for replacement of these parts.

If rear axle or wheel is sprung by skidding against a curb or other accident, it is false economy to drive it. Tires, gears, and all other parts will suffer, and the bill for repairs will grow daily. If axle shaft is bent, it is better to get a new one than try to straighten the old one.

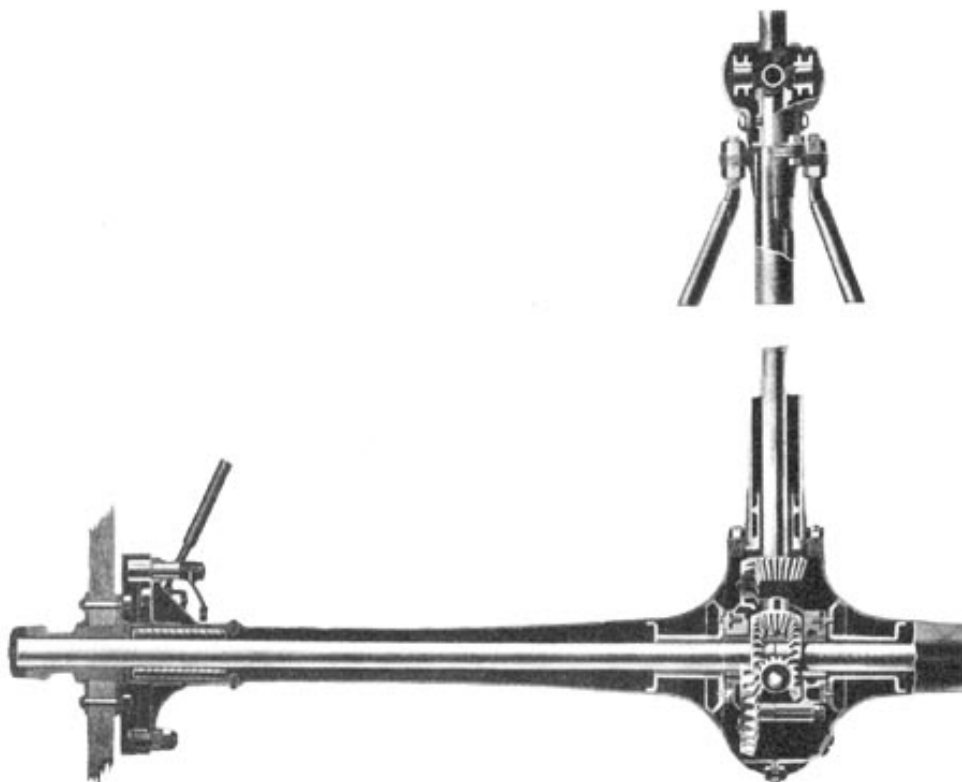

**RECHARGING MAGNETS WITHOUT THE USE OF THE MAGNET CHARGER**

Five or six 6-volt 40 ampere storage batteries should be used to furnish the necessary current and should be connected as shown in the diagram.

The first step is to get the magneto in proper position to receive the current. To do this, hold a compass over the transmission cover, as shown in the diagram, and turn the motor over slowly until the end of the compass which normally points north will point to a spot about one-fourth of an inch from the side of the fiber at the bottom of the contact assembly on transmission cover.

Next disconnect the wire leading to the dash coil from the contact assembly, and attach instead the wire leading from the positive pole of the battery. You are now in a position to use the current. To do this, make and break the circuit by striking the wire leading from the negative pole of the battery against some part of the motor. About twenty contacts should be sufficient to fully recharge the magnets.

Be sure that you do not connect the negative pole of the battery with the contact assembly, and see that the compass indicates that the magnets are in the position as described above-otherwise, the magnets will be weakened instead of being re-charged.

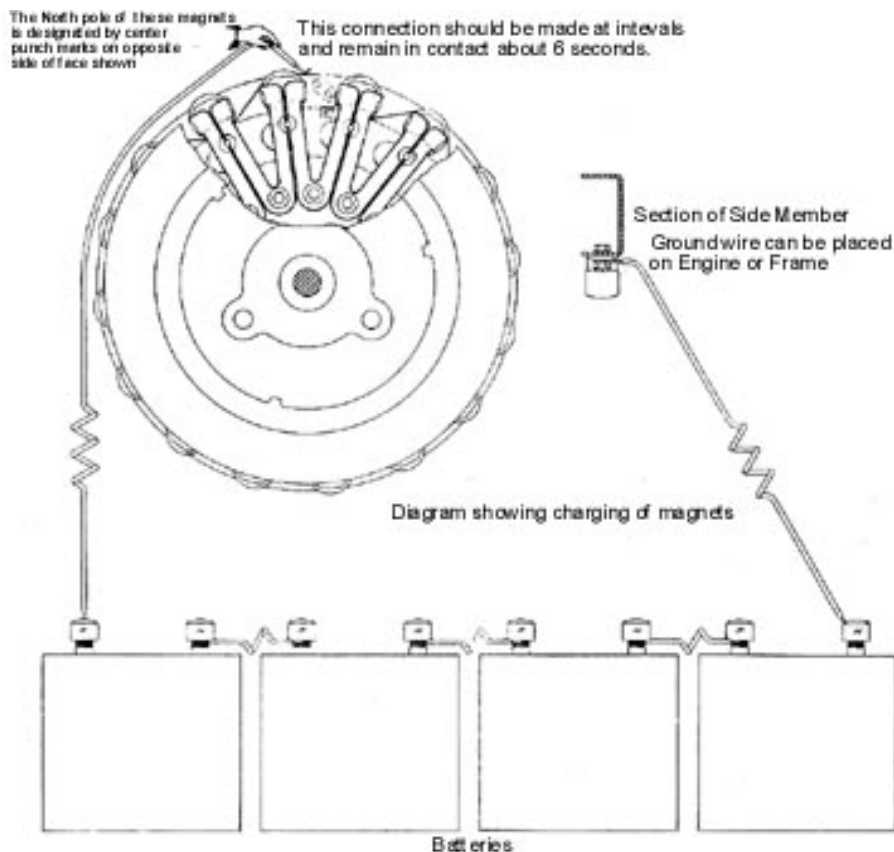

### DIRECTIONS FOR INSTALLING NEW MAGNETS

If you are unable to obtain storage batteries for this work, it would be advisable to return the magnets to the factory in exchange for a new set. In reassembling the magnets on the fly-wheel care must be given to see that they are placed in the same relative position as before, that is, the negative or south poles together, so there will be no attraction between the individual magnets.

The magnets when shipped will be arranged on a board in the proper manner, and should not be removed until placed in position on the fly-wheel. The magnets should travel at a distance of  $1/32$ " from the face of the coil fields, and this distance should be uniform all the way around. In case the coils do not set close enough, a metal shim can be placed between the coil support and cylinder casting. If the coils are too near the magnets, the coil support can be bent backward until the proper distance is secured. Be sure, however, that the same distance is maintained between each magnet and the coil field, otherwise the ignition would be irregular.

### RECHARGING MAGNETS BY MEANS OF MAGNET CHARGER

The illustration shows a new charging device for Model "T" magnets. Its use greatly simplifies matters, as it requires only six volts (three cells) of storage, or five dry cells. It is also supplied for use on one hundred and ten volt direct current lighting or power circuits. This latter style can be used on a two hundred and twenty volt D. C. circuit by placing one two hundred and twenty volt lamp in series with the charging device.

Fig. 1 shows method of using compass to determine polarity after current wires are attached to charger, and will show whether positive current wire has or has not been connected to positive terminal of charger-if connected wrong, reverse connections. North pole of compass should point to pole marked N on magnet charger. Do not use a six volt charger on a one hundred and ten volt circuit or a one hundred and ten volt charger on a six volt circuit. Charger will not work on alternating current.

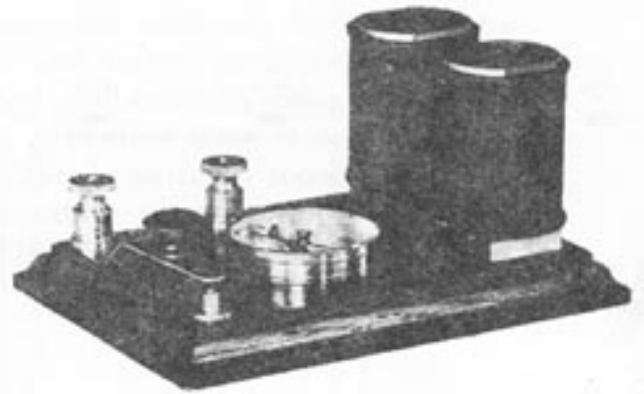

The Model T Magnet Charger

Connect battery or circuit wires to charger terminals with smooth side of magnet face [down, place north pole of magnet on spool or coil marked "N," and hold in position, as shown. With other hand manipulate interrupter by pressing once a second for twenty-five or thirty seconds. Before drawing magnet away, place small wire nail or other iron or steel cross piece over terminals to act as keeper.

Half the magnets will be recharged, as in Fig. 2, the balance, as Fig. 3, as the poles correspond only in every other magnet.

In remounting magnets on flywheel, care must be exercised to arrange same so that north poles are next to north poles; south poles to south poles.

Price \$10.00 includes compass.



Finding the Polarity



Charging one Magnet

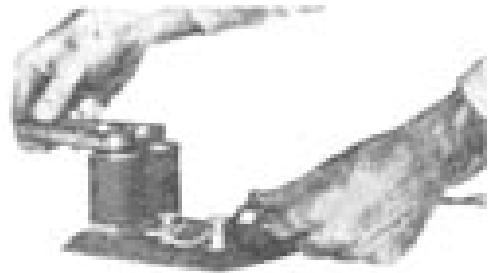

Charging the one next to it

**CARBURETION**

As the symptoms of carburetor and ignition "troubles" are practically the same, we give below some of the principal difficulties and their causes.

Mis-firing, or loss of power, may be caused by dirt or water in the carburetor, obstructed feed pipe, clogged spraying nozzle, bent or grooves adjusting needle, mixture too lean or too rich, fuel logged float, or a poor grade of gasoline.

A rich mixture will not only quickly foul up the cylinders, pistons and valves with soot, but will tend to over-heat the cylinders, and is likewise wasteful of the fuel. It will often choke the engine and cause mis-firing at slow speeds, although at high speeds the machine will run perfectly. The mixture should be kept as lean as possible and at the same time obtain the full power of the motor.

A weak mixture will often result in back-firing through the carburetor, for the reason that the gas burns slowly in the cylinder, and is still burning when the inlet valve opens again, which causes the gas in the intake pipe to ignite.

The usual method of regulating the carburetor is to start the motor, advancing the throttle lever to about the sixth notch with the spark retarded. The flow of gasoline should now be cut off by screwing down in the needle valve until the engine begins to mis-fire; then gradually increase the gasoline feed by opening the needle valve until the motor picks up and reaches its highest speed, and until no trace of black smoke comes from the exhaust. Having determined the point where the motor runs at its maximum speed, the needle valve binding screw should be tightened to prevent the adjustment being disturbed.

A cork float which has become fuel-soaked should be removed and thoroughly dried out, then given a couple coats of shellac varnish to make it waterproof. If the float is adjusted too low, starting will be difficult, if too high it will cause the carburetor to flood or leak.

The spraying nozzle having a very small opening, a minute particle of grit or other foreign matter will clog up the orifice, and as a result the motor will begin to mis-fire and slow down as soon as it has attained any considerable speed. This is accounted for by the fact that at high speeds the increased suction will draw the particles of dust, etc., into the nozzle, whereas with the reduced suction at slow speed the obstruction will fall away from the nozzle. In any case if the valve seat is rough, it should be ground by applying a little pumice or fine emery and oil to the seat, and rotating the needle valve until both are smooth and bright. The needle which has been grooved by the valve seat may be smoothed off by the use of a fine file.

The presence of water in the carburetor or gasoline tank, even in small amounts, will prevent easy starting and the motor will mis-fire and stop. As water is heavier than gasoline it settles to the bottom of the tank and into the sediment bulb along with other foreign matter. It is, therefore, a good plan to occasionally drain the tank by opening the pet cock at the bottom of the sediment bulb. This will prevent the possibility of an over-accumulation of waste matter which might otherwise work down into the carburetor through the gasoline tank. The careful driver will prefer to take the extra trouble of straining the gasoline through chamois skin when filling a tank.

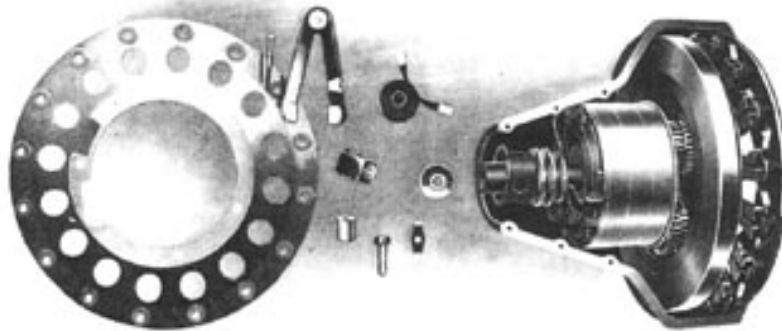

Model T Magneto and Parts

## SUGGESTIONS FOR STARTING IN COLD WEATHER

- 1st. Shut off gasoline by turning adjustment in dash.
- 2nd. Crank engine-three or four turns.
- 3rd. Turn on gasoline three or four full turns and flood carburetor.
- 4th. With throttle and spark levers in starting position: start motor and adjust carburetor.

## SOME HINTS ON THE CARE OF TIRES

Tire cost constitutes one of the most important items among the running expenses of an automobile. Tires should never be run partially deflated, as the side walls are unduly bent and the fabric is subject to stresses which cause what is known as rim cutting. When a car is idle for any appreciable length of time, it should be jacked up to take the load off the tires. If the car is laid up for many months, it is best to remove the tires and wrap up the outer covers and inner tubes separately, and store them in a dark room not exposed to extreme temperatures.

To prolong the life of outer casings they must be closely watched for cuts and tears developing in the tread. If the cut does not extend entirely through the rubber portion of the tread, it may be filled with tire cement and then vulcanized. When deep cuts are suffered, it is best to send the tire to the makers and have it repaired there.

Under ordinary conditions the rear tires wear much faster than the front on account of carrying the heavier load, and the wear is still further augmented by the action of the brakes in making sudden stops.

In case the front tires wear faster than the rear, it is very likely that the front wheels are out of alignment. This condition may be due to the steering spindle connecting rod being improperly adjusted, or the steering spindle arms bent.

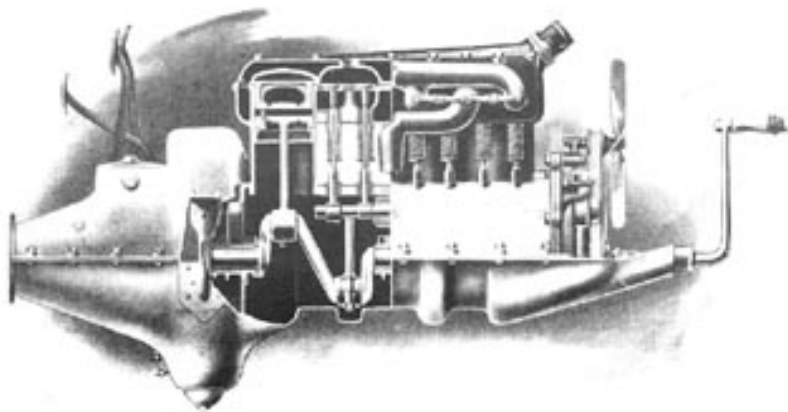

Semi-Sectional View of the Model T Motor